

OL 700-30

Goniometric Measurement Assembly

The OL 700-30 Goniometric Measurement Assembly (*goniometer*) is designed to operate with the OL 770-LED high-speed Multichannel LED Test & Measurement System. The OL 770-LED Windows® based application software provides complete control of the OL 700-30 goniometer with a comprehensive suite of spatial radiation measurement routines.

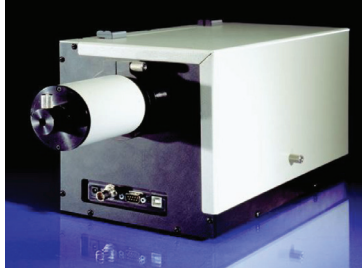

The OL 700-30 goniometer also features ActiveX™ controls and a software development kit (SDK). This enables the instrument to accommodate custom applications as developed by the user, including applications independent of the OL 770-LED.

The lightweight, small footprint design makes the OL 700-30 ideal for QA and production floor DUT spot checks.

SPECIFICATIONS

Automated Horizontal Range, θ	-90° to +90°
Minimum Horizontal Angle Resolution	0.01°
Angular Accuracy*	0.001°
Maximum Horizontal Rotation Rate @ 1° Measurement Interval	15° per second
Manual Axial Range, ϕ	-90° to +90°
Minimum Horizontal Angle Resolution	10°
Computer Interface	USB
Power Requirement	External 12 VDC / 800mA Main Adapter (<i>Supplied</i>)
Single Linear Positioning Stage with Center of Rotation Tool	≤ 12 mm Linear Travel
Test Device Interface	Banana Jack (3)
Outputs	TTL Trigger Output to Measurement Device (BNC)
Dimensions	12.5" x 6.5" x 8" (31.75 cm x 16.51 cm x 20.32 cm)
Weight	14.5 lbs. (6.6 kg)
Enclosure	Black Anodized Aluminum, Light Resistant Enclosure
*Accumulative error for each movement (start – stop) with allowance for backlash	

Measurements



- View angle
- Lab/Luv vs angle
- Purity vs angle
- Maximum intensity versus angle
- Peak wavelength versus angle
- Dominant wavelength vs angle
- Tristimulus versus angle
- CRI vs angle
- Power vs angle
- Relative power vs angle
- Half bandwidth versus angle
- Color temperature versus angle
- Chromaticity versus angle

Design Features



- Comprehensive suite of spatial radiation distribution measurements
- High-speed USB interface
- Powerful measurement software included
- Graphical presentation of any parameter vs. angle
- Easily customizable with ActiveX™ controls
- Lightweight, small footprint design
- Conforms to CIE Publication 127 Condition A for Averaged LED Radiant Intensity Measurements*

*Requires OL 15AB Led Receptor or OL 700-30A Condition A Tube

Software Features



- Graphical presentation of any parameter vs. angle
- Automated view angle calculation
- Toggle from spatial graph to spectral scan at any angle
- Send plots/data to MS Word®
- Send data to MS Excel®
- Goniometric file save/ load
- Polar plot cursors controlled by mouse
- Cursor difference measurements
- Peak snap cursor function
- CIE plot at each angle
- Manual angle control
- Software Developers' Kit included

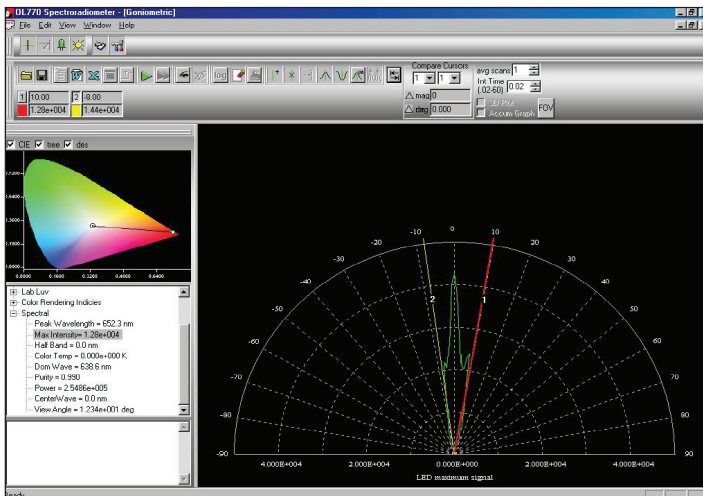
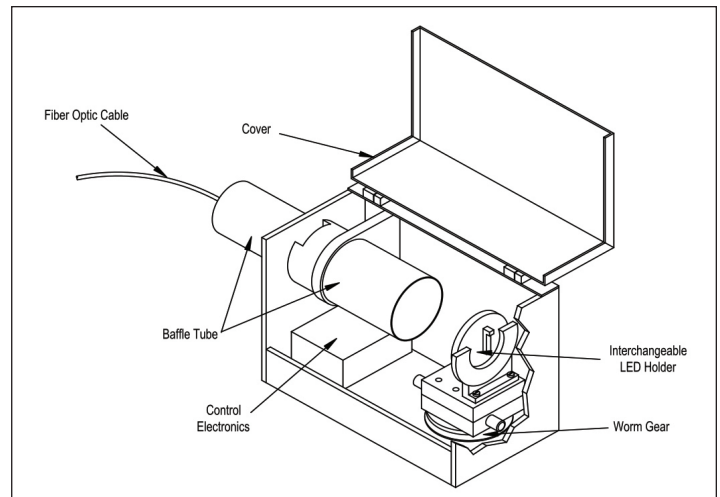

Spatial Scan of Red LED – Maximum Intensity vs. Angle

OPTRONIC™
LABORATORIES

Data sheet: B099 Sept 2018

As part of our policy of continuous product improvement, we reserve the right to change specifications at any time.